

CenturyLink® Cloud Connect: MPLS/IPVPN to AWS (Hosted)

Direct, Secure, Private Connection to AWS

Content

- Purpose (slide 2)
- Contents / Steps with links (slide 3)
- Background Information (slides 4-5)
- Topology (slide 6)
- Roles and Responsibilities (slide 7)
- Requesting CTL Cloud Connect (slide 8)
- CTL Provisioning Cloud Connect (slide 9)
- Accepting the Hosted Connection (slides 10-11)
- AWS Direct Connect Resources (slide 12)

January 9th, 2019

Purpose

The purpose of this document is to provide an end-to-end walk through for a customer setting up Hosted Direct Connect for the first time via CenturyLink's Cloud Connect.

Information contained is provided to serve as a supplement to AWS documentation linked throughout this document. Users should check the provided links to obtain the most up-to-date information and for more details pertaining to AWS processes.

Disclaimer: The material in this guide is for informational purposes only and is taken from AWS's website material. All AWS related configuration information is based off of the AWS Console configuration instructions from the AWS website.

Contents / Steps

1. [Background Information – What is Direct Connect](#)
2. [Background Information – Getting Started with AWS Direct Connect](#)
3. [Topology - Hosted Cloud Connect for AWS Direct Connect](#)
4. [Roles and Responsibilities](#)
5. [Customer requests CenturyLink Cloud Connect service](#)
6. [CenturyLink Provisions Cloud Connect to AWS](#)
7. [Accepting the AWS Hosted Connection](#)
8. [AWS Direct Connect Resources](#)

1) Background Information

What is AWS Direct Connect (<https://aws.amazon.com/directconnect/>)

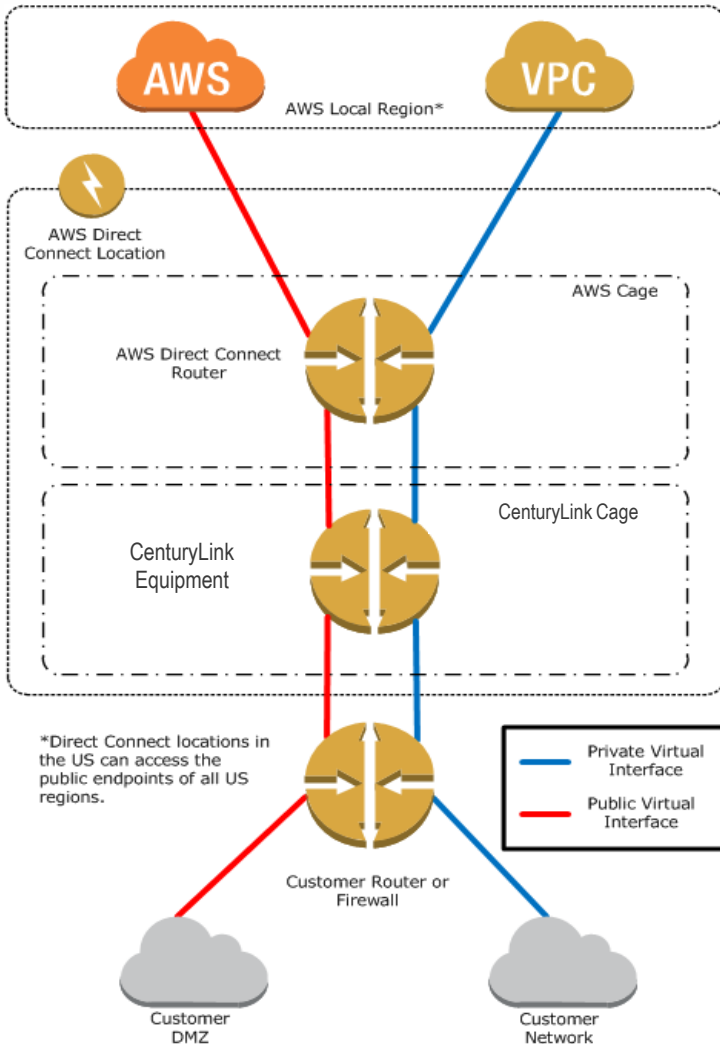

AWS Direct Connect links your internal network to an AWS Direct Connect location.

One end of the connection is connected to your network, the other to an AWS Direct Connect router.

With this connection in place, you can create virtual interfaces directly to the AWS cloud services, bypassing the public Internet.

An AWS Direct Connect location provides access to Amazon Web Services in the region it is associated with, as well as access to other US regions.

For example, you can provision a single connection to any AWS Direct Connect location in the US and use it to access public AWS services in all US Regions.

2) Background Information

Getting Started with AWS Direct Connect (<https://aws.amazon.com/directconnect/getting-started/>)

- This document is for hosted connections via AWS Direct Connect.
- The supporting service ordered from CenturyLink is Hosted Cloud Connect to AWS.
- The 3rd option in the 3 scenarios below (screenshot from the AWS Direct Connect Getting Started webpage – link above) is applicable to this CenturyLink service type.

Getting started with AWS Direct Connect

AWS Direct Connect enables you to directly interface your on-premises network with a device at an AWS Direct Connect location. The following procedures demonstrate the common scenarios to get set up with an AWS Direct Connect connection. You can also refer to the article [How do I provision an AWS Direct Connect connection?](#) in the Knowledge Center.

You can set up an AWS Direct Connect connection in one of the following ways.

Scenario	Method
Present at AWS Direct Connect Location	Connect directly to an AWS device from your router at an AWS Direct Connect location using 1Gbps or 10Gbps connection.
Connect from your premises	Work with a partner in the AWS Partner Network (APN) or a network provider that will help you connect a router from your data center, office, or colocation environment to an AWS Direct Connect location. The network provider does not have to be a member of the APN to connect you.
Connection via AWS Direct Connect Partner	Work with a partner in the AWS Partner Network (APN) who will create a hosted connection for you. Sign up for AWS, and then follow the instructions to accept your hosted connection .

3) Topology - Hosted Cloud Connect for AWS Direct Connect

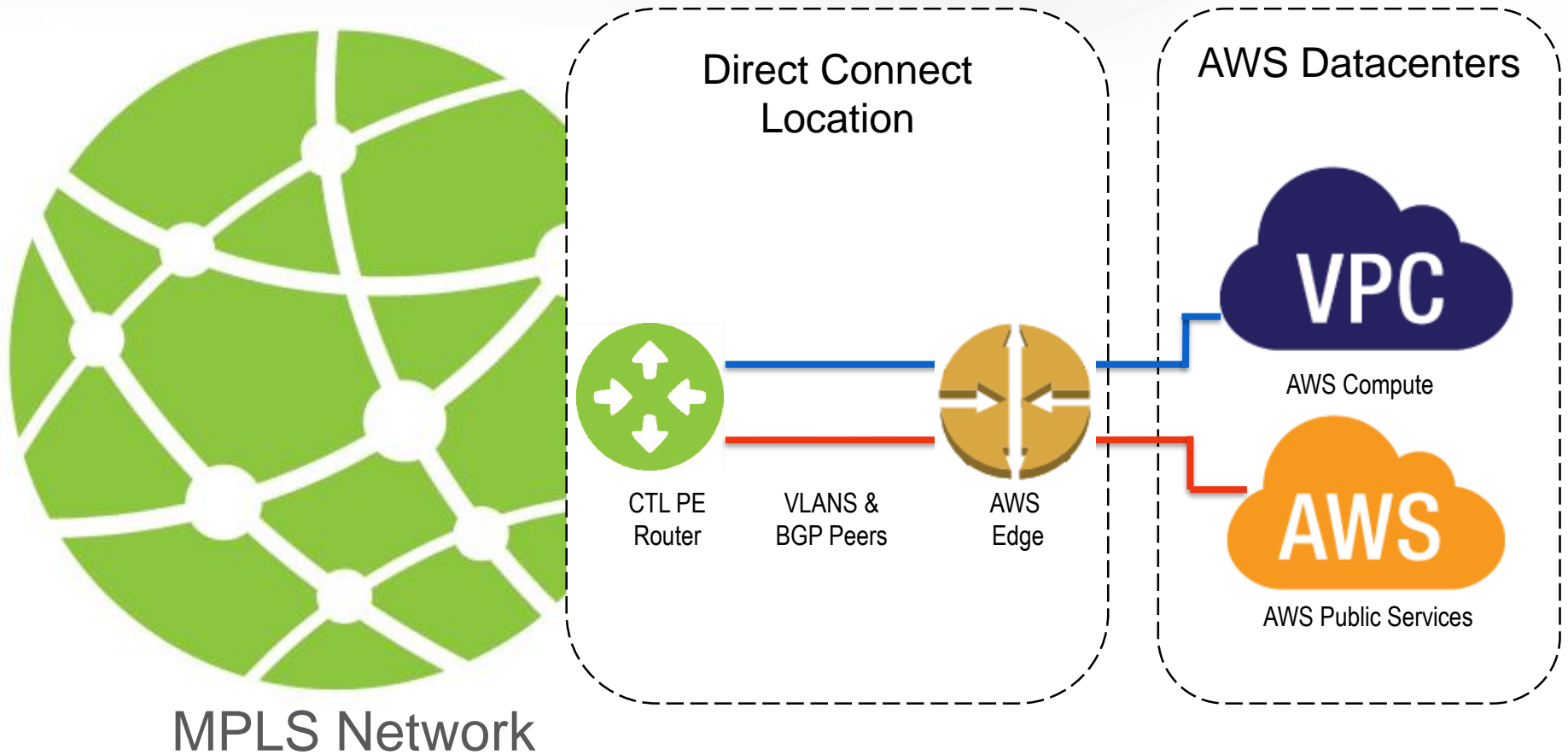

- Any NAT configuration that is required due to the use of any AWS Public Services will be the responsibility of the customer.

4) Roles and Responsibilities

Roles and Responsibilities			
STEPS REQUIRED TO SET UP AWS DIRECT CONNECT CONNECTIVITY	END CUSTOMER	CENTURYLINK	AWS
SET UP CONNECTIVITY TO AWS DIRECT CONNECT LOCATION			
Order CenturyLink Hosted Cloud Connect service(s) to AWS Direct Connect	X		
Decide on the type of VIF required (public or private)	X		
Create Virtual Circuit to AWS		X	
Monitor Virtual Circuit to AWS		X	
SET UP BGP PEERING BETWEEN CENTURYLINK PE AND AWS EDGE DEVICE			
Configure BGP Peering on CenturyLink PE Router facing AWS		X	
Configure BGP Peering on AWS side via Portal facing CenturyLink		X	
LINK SERVICES ON AWS TO THE DEDICATED CIRCUIT/HOSTED CONNECTION			
Accept Hosted Connection via AWS Portal	X		
Create & link Virtual Interface, Virtual Private Gateway, Direct Connect Gateway etc.. As applicable via AWS Console	X		

5) Customer requests CenturyLink Cloud Connect service

- To order a CenturyLink Cloud Connect to AWS Direct Connect, contact your CenturyLink Account Representative
- Information needed by CenturyLink to complete the connection:
 - AWS Account ID
 - AWS service(s) you are connecting to
 - Public Virtual Interface (VIF) Requirements
 - Virtual Private Cloud (VPC) / Virtual Interface (VIF) Requirements
 - Identify how many VPC's/VIF's you need connectivity to
 - Each VPC/VIF requires a separate logical connection with hosted Cloud Connect from CenturyLink
 - Determine the amount of bandwidth needed to each VPC/VIF
 - Note: Maximum bandwidth per VPC/VIF is 500megs
 - Which AWS Region and/or Direct Connect location do you require connectivity to
 - What contractual term length is desired (1yr, 3yr, 5yr etc...)

6) CenturyLink Provisions Cloud Connect to AWS

- **Upon network order submission, CenturyLink will provision a Layer 3 IPVPN MPLS connection to the requested interconnect point**
 - CenturyLink will configure VLAN Tagging and Layer 3 BGP Routing on both the CenturyLink side and within the AWS console.
- **CenturyLink completes configuration, and provides Customer with necessary information documenting the Layer 3 turn up on AWS side per environment**
 - Appropriate IP subnet(s)
 - Autonomous System Number (ASN) Info
 - AS Number
 - BGP Authorization Key
 - VLAN ID

7) Accepting the AWS Hosted Connection

(https://docs.aws.amazon.com/directconnect/latest/UserGuide/getting_started.html)

- For instructions on how to accept the AWS Hosted Connection within the AWS Console, please navigate to this link → [accept your hosted connection](#)
- The screenshot below has the 3 different AWS Direct Connect options. Note that for CenturyLink Hosted Cloud Connect service the 3rd option is applicable.

You can set up an AWS Direct Connect connection in one of the following ways.

Port speed	Method
1 Gbps or higher	Connect directly to an AWS device from your router at an AWS Direct Connect location.
1 Gbps or higher	Work with a partner in the AWS Partner Network or a network provider to connect a router from your data center, office, or colocation environment to an AWS Direct Connect location. The network provider does not have to be a member of the APN to connect you.
Less than 1 Gbps	Work with a partner in the AWS Partner Network who can create a hosted connection for you. Sign up for AWS and then follow the instructions to accept your hosted connection .

Accepting the AWS Hosted Connection (cont'd)

https://docs.aws.amazon.com/directconnect/latest/UserGuide/getting_started.html

If you requested a hosted connection via CenturyLink Cloud Connect then a hosted connection has been created for you (you cannot create it yourself). You must accept it in the AWS Direct Connect console before you can create a virtual interface.

To accept a hosted connection:

- Open the AWS Direct Connect console at <https://console.aws.amazon.com/directconnect/>.
 - If necessary, select the Region in which the hosted connection resides.
 - In the navigation pane, choose 'Connections'.
 - Select the hosted connection.
 - Select the confirmation check box and choose 'Accept Connection'.
- Continue to follow the AWS guidance at this same page for instructions on setting up your AWS Direct Connect connection. -

https://docs.aws.amazon.com/directconnect/latest/UserGuide/getting_started.html

8) AWS Direct Connect Resources

Overview	https://aws.amazon.com/directconnect/
Details	http://docs.aws.amazon.com/directconnect/latest/UserGuide/Welcome.html
VPC Endpoints	http://docs.aws.amazon.com/AmazonVPC/latest/UserGuide/vpc-endpoints.html
Pricing	https://aws.amazon.com/directconnect/pricing/ <ul style="list-style-type: none">• There are different price rates for traffic to the local AWS region and remote AWS regions
FAQ	https://aws.amazon.com/directconnect/faqs/
How to configure	http://docs.aws.amazon.com/directconnect/latest/UserGuide/getstarted_sub1g_provider.html
AWS Direct Connect Limits	https://docs.aws.amazon.com/directconnect/latest/UserGuide/Welcome.html#directconnect_limits
Notes	<ul style="list-style-type: none">• Traffic to/From AWS is rate limited to a maximum of 500 Mb when using a hosted connection. Higher bandwidths are available from CenturyLink and AWS via Dedicated Cross Connect solutions. See your CenturyLink account team for more details.• A single CenturyLink Hosted Cloud Connect service will support a single Hosted Connection to a single Virtual Interface (VIF) / VPC or a single Direct Connect Gateway. To support additional VIFs/VPCs/Direct Connect Gateways, please order additional Hosted Cloud Connect logical connections.